



CITROËN DS3





IT'S ALL ABOUT PERSEVERANCE. YOU CAN HAVE A GREAT
IDEA BUT IF YOU DON'T FIGHT, IT WON'T GO ANYWHERE.

THIERRY METROZ
DESIGN DIRECTOR

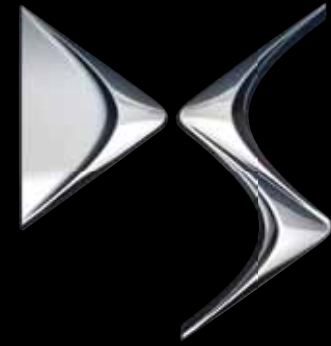

D S L I N E

EVERY LINE IS JUSTIFIED BY A FUNCTION.

MARK LLOYD
STYLING MANAGER



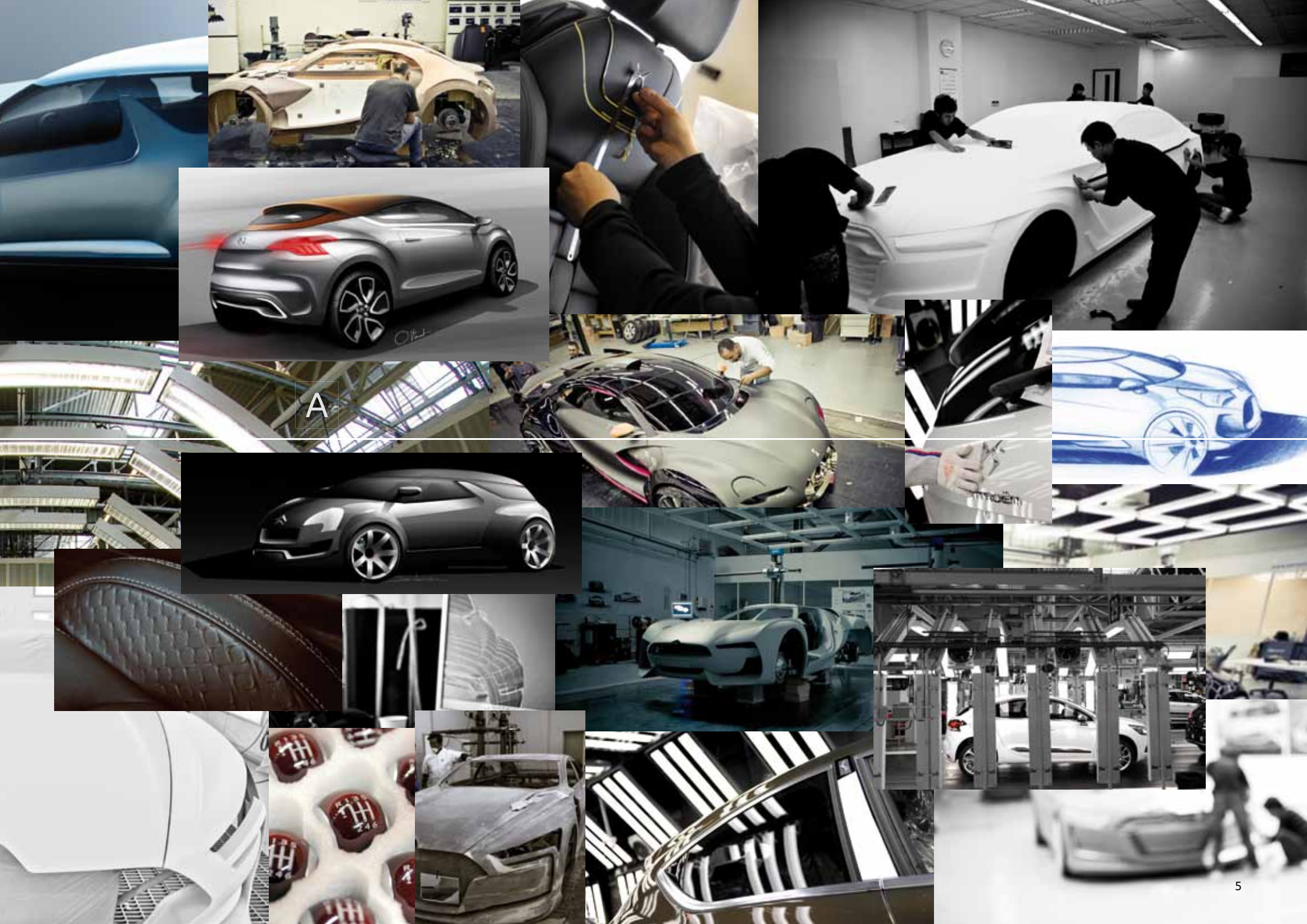

A



D E S I G N



A



THOMAS D'HAUSSY
RANGE MANAGER

DESIGN



Sculpted flowing forms reflect Citroën DS3's refined dynamic performance, yet we've maintained a taught compactness in the profile. We were keen to create elements of genuine surprise within its design character as well, clearly epitomised by the dramatic shark fin B pillar – like the design as a whole, that shape is fast becoming a bit of an icon.



CHRISTOPHE POINLANE
COLOURS AND MATERIALS STYLIST

COMFORT



You become one with Citroën DS3 when you get in and drive. A big part of that process is about true comfort – it's in the high quality materials that surround you and that you touch, the layout of the controls, the technology... there's an engineered refinement that begins at ground level and is appealing in every sense.

THIERRY METROZ
DESIGN DIRECTOR

INDIVIDUAL



When we created Citroën DS3, we aimed to provide maximum freedom for individual expression – to make it the antithesis of ‘me too’ and generic design. I believe it raises the bar for this kind of personal creative involvement, because the unique character and charisma of the car demand that you make it yours.



MARK LLOYD
STYLING MANAGER

STYLE



I think there's an innate desirability about Citroën DS3. There are all kinds of unmistakable style cues that simply belong to this car – that you won't find anywhere else. True style grabs your attention – either at a glance or up close: it's in the magnetism of the whole – its street presence – and in all the details.



ANTI RETRO. EACH ELEMENT AND EVERY ANGLE OF CITROËN DS3 IS 100% NEW: FRESH, ORIGINAL AND INNOVATIVE; ADVANCED AND RADICALLY DIFFERENT FROM OTHER CARS, IT IS A CLEAR EXPRESSION AND CELEBRATION OF CRÉATIVE TECHNOLOGIE.

BUT CITROËN DS3 IS ALSO ABOUT YOU, BECAUSE THROUGH ITS HUGE RANGE OF PERSONALISATION OPTIONS, IT ALLOWS YOU TO FINE TUNE A CAR THAT REFLECTS YOUR CHARACTER AND TASTE MORE CLEARLY AND STYLISHLY THAN EVER. THROUGH ELEGANT DESIGN, TACTILE QUALITY AND ADVANCED TECHNOLOGY, CITROËN DS3 TAKES FREEDOM OF EXPRESSION TO THE NEXT LEVEL.

› CITROËN DS3 CROWNED TOPGEAR MAGAZINE 'CAR OF THE YEAR'

TopGear magazine have awarded Citroën DS3 with its 'Small Car of the Year' accolade as well as the coveted 'Car of the Year' title in its 2010 awards.



› **CONTENTS:** 12 INTRODUCTION 14 OUTSIDE 16 INDIVIDUALITY 18 DRIVING EXPERIENCE 20 INSIDE 22 TECHNOLOGY & INNOVATION 24 SAFE & EFFICIENT 26 THE RANGE 28 YOUR EXTERIOR 30 YOUR INTERIOR 32 EQUIPMENT SPECIFICATION 34 TECHNICAL SPECIFICATION 36 ACCESSORIES 37 ENVIRONMENTAL COMMITMENT 38 FINANCE, CARE & INSURANCE 39 GLOSSARY & DIMENSIONS

INSTANTLY ICONIC. CITROËN DS3 CREATES ITS OWN CLASS AND A NEW TRADITION. EVEN PARKED IT HAS A SUBTLE DYNAMISM AND SENSE OF MOVEMENT, THANKS TO INSPIRING DESIGN SURFACES AND SHAPES.

THE WHOLE PROFILE IS ROBUST AND CHUNKY, YET SMOOTH AND REFINED. A UNIQUE 'SHARK FIN' B PILLAR SWEEPS TOWARDS THE 'FLOATING' ROOFLINE, WHILE TWO ROWS OF SPARKLING LEDS CAN FLANK THE AGGRESSIVE, ROAD HUGGING LOWER GRILLE AND SPOTLIGHTS. THE CHROMED UPPER GRILLE ELEGANTLY INCORPORATES THE DOUBLE CHEVRON. TAKE TIME TO LOOK FROM ANY ANGLE AND YOU'LL FIND SURPRISES, ORIGINAL IDEAS AND DELIGHTFUL DETAILS: A DESIGN ICON FOR NOW.





FORCE OF PERSONALITY. CITROËN DS3 CAN BE AS INDIVIDUAL AS A SIGNATURE. WITH NO FEWER THAN 11 STUNNING BODY COLOUR CHOICES AND 4 CONTRASTING SHADES FOR THE FLOATING ROOF PANEL, THE POTENTIAL FOR PERSONAL EXPRESSION IS VAST.

THE 16" OR 17" ALLOYS CAN BE PURE METAL OR PAINTED, AND AN EXCITING SELECTION OF ROOF GRAPHICS IS READY TO ADD HEAD-TURNING IMPACT. THE BOLD CURVING DASH COMES IN SIX STRIKING FINISHES AND EVEN THE REMOTE PLIP FEATURES A COLOURED DISC – A PERFECT LITTLE SYMBOL OF ULTIMATE PERSONALISATION!







A MOVING EXPERIENCE. NOTHING FEELS LIKE CITROËN DS3 ON THE MOVE: HERE'S A DRIVING EXPERIENCE LIKE NO OTHER. IT STARTS AS YOU SETTLE INTO THE SCULPTED, BEAUTIFULLY FINISHED DRIVING SEAT THAT'S SET SPORTY AND LOW.

THE COMPACT STEERING WHEEL FEELS JUST RIGHT AND ALL THE VITAL DIALS ARE SET IN A DEEPLY COWLED, CHROME-EDGED TRIPLE POD. TURN THE KEY AND BOTH SPEEDO AND REV COUNTER ZIP ROUND THEIR DIALS AND RETURN TO ZERO. YOU'RE READY TO GO.

There are three petrol engines, from the VTi 95 and VTi 120, to the exciting THP 155, and two supereconomical diesels of 90hp or 110hp, including one of the e-HDi DStyle models which produces an incredible 95g/km of CO₂. All engines balance refined power and the need for cleaner, greener driving.

› ROLLING SCULPTURE

Stunning alloy wheels hint at Citroën DS3's poise and finely tuned handling.

› POWERFUL PERSONALITY

From 95g/km of CO₂ to 155hp with a double exhaust, Citroën DS3 offers a diverse choice of engines for a perfect blend of fun and efficiency.





0 1 2 3 4 5 6 7
X 1000

10 30 50 70 90 110 130 150 170 190 210
CITROËN
mph
F

14.2 miles
0000 18 miles
1/2





LUXURY REINVENTED. THE CITROËN DS3 INSIDE STORY IS AN ORIGINAL. LOOK AROUND AND YOU'LL SEE INVITING, SERIOUSLY ENVELOPING SEATS, STYLISH AND CRYSTAL CLEAR INSTRUMENTS AND PERFECTLY HONED DETAILS, ALL IN HIGH QUALITY, TACTILE MATERIALS.

BRUSHED METAL, POLISHED CHROME AND LEATHER MAKE IT A SENSORY TREAT. ON DSTYLE AND DSPORT MODELS, THE GEAR KNOB MIXES MATT CHROME WITH LEATHER AND THE BODY HUGGING DRIVER'S SEAT IS FULLY ADJUSTABLE. AN OPTIONAL RETRACTABLE FRONT ARMREST ALSO FUNCTIONS AS A USEFUL STORAGE SPACE. EVERYWHERE THERE ARE BIG CAR REFINEMENTS AND INNOVATIVE LUXURY DETAILS, REDEFINED FOR CITROËN DS3.

> PEDAL POWER

On DSport models the tough, stylish, aluminium pedals have grippy rubber inserts for perfect footwork – DSign and DStyle models get an identical set if you order the optional Sirocco 'Akinen' cloth.



> SENSUAL WORLD

Lustrous finishes, supple leather and fresh shapes are a treat for your senses.

> ELEGANT COMFORT

The added comfort of an optional central armrest features a handy storage compartment.



INNOVATION EVERYWHERE. ADVANCED TECHNOLOGY AND INTELLIGENT DETAILS CAN BE SEEN EVERYWHERE ON CITROËN DS3. LIKE EVERY CITROËN, IT HAS INNOVATION IN ITS DNA.

THE RDS RADIO/MP3 COMPATIBLE CD PLAYER AND THE AUXILIARY SOCKET CAN BE DRAMATICALLY TRANSFORMED BY THE POWERFUL HI-FI SYSTEM. YOU CAN ALSO SELECT EMYWAY SAT NAV WITH EUROPEAN MAPPING, WHICH PROVIDES AERIAL VIEW DISPLAYS ON A 7" 16/9 SCREEN. ALSO AVAILABLE, A HEAD TURNING SIGNATURE OF CITROËN DS3 IS ITS STYLISH, SAFE DAY RUNNING LEDS THAT SPARKLE EITHER SIDE OF THE LOWER GRILLE.

> EFFORTLESS COOL

Automatic air conditioning – standard on DSport models – maintains an ideal interior temperature and is easy to adjust using the two clever multi-function dials.

> EMYWAY – YOUR WAY

Choose eMyWay sat nav with 7" colour screen and get to any European destination minus hassle.

> FRONT ROW SEATS

With the Hi-Fi standard on DSport and optional on DSign and DStyle, a third central speaker in the dashboard puts you at the heart of every song.



> LOOKS GOOD, IS GOOD

The bold curves of the dashboard, with its chrome trimmed dials and fingertip controls house all your chosen technology: form and function in perfect harmony! Even the key clip is a little personalised work of art.

> MAKE THE CONNECTION

Part of the Connect Signature, standard on DSport and optional on other models, a USB dock nesting in the centre console means that Citroën DS3 can talk to your MP3 or a USB stick.



IT'S YOUR WORLD. CITROËN DS3 IS FOR INDIVIDUALS, AND CITROËN UNDERSTANDS THAT PROTECTING YOUR LOVED ONES WHILE MINIMISING ENVIRONMENTAL IMPACT ARE IMPORTANT PERSONAL CHOICES.

THAT'S WHY ALL CITROËN DS3 MODELS HAVE STANDARD ESP, ABS WITH ELECTRONIC BRAKEFORCE DISTRIBUTION (EBD) AND EMERGENCY BRAKING ASSISTANCE (EBA), WHILE THE INTERIOR FEATURES NO FEWER THAN SIX AIRBAGS. THE EURO NCAP TEST HAS RECOGNISED CITROËN DS3'S ADVANCES, BY AWARDING IT THE MAXIMUM 5 STAR SAFETY RATING.

Engineered to be light and fuel efficient, all e-HDi versions emit less than 100g/km CO₂, while one of the e-HDi 90 manual models manages an amazing 95g/km CO₂. Citroën DS3 can be all about you and better for everyone.



> SAFELY ANCHORED

Child safety is as important to us as it is to you. Isofix anchorage points on the outer rear seats ensure that children are safe and secure.



> CHANGE FOR GOOD

Citroën DS3 helps you drive with the environment in mind thanks to its Gear Efficiency Indicator (GEI) on manual models, which lets you know exactly which gear is most efficient and reduces the ecological impact and fuel consumption.



CITROËN DS3

TAKE THREE INDIVIDUALS.
CITROËN DS3 IS A RANGE
OF THREE MODELS. THEY
ARE POINTS OF DEPARTURE
FOR YOUR INDIVIDUALITY.
HERE IS WHERE YOUR
OWN DS3 COMES ALIVE.

WHETHER YOU GO FOR DSIGN, DSTYLE OR DSPORT,
YOU WILL BE STARTING WITH A BEAUTIFULLY STYLED
AND BRILLIANTLY ENGINEERED CITROËN: WHERE
BETTER TO BEGIN?



> CITROËN DS3 DSIGN



> CITROËN DS3 DSTYLE



> CITROËN DS3 DSPORT

DSIGN

A DRAMATIC ENTRANCE

FASCINATING FROM EVERY ANGLE, TEEMING WITH GREAT DETAILS AND READY TO RAISE A GRIN ON ANY DRIVE, CITROËN DS3 DSIGN HAS A VERY NON-STANDARD STANDARD SPECIFICATION THAT BRINGS YOU THE FEATURES AND TECHNOLOGY THAT MATTER.

> CITROËN DS3 **DSIGN** SPECIFICATION INCLUDES:

- ABS with Electronic Brakeforce Distribution (EBD) and Emergency Braking Assistance (EBA)
- Electronic Stability Programme (ESP)
- Driver's, front passenger's, front lateral and curtain airbags
- Front seat belt pre-tensioners with force-limiters
- Front fog lights
- Cruise control with speed limiter
- Gear Efficiency Indicator (manual models only)
- Variable power assisted steering
- Sport suspension
- High-frequency remote control central locking with deadlocks
- RDS stereo radio/MP3 compatible CD player with steering mounted controls and six speakers
- Auxiliary socket
- Electrically adjustable door mirrors
- Front electric windows with 'one-touch' operation on driver's side
- Rear 1/3-2/3 split/folding seats
- 12 volt socket
- Multi-function on-board trip computer
- 16" 'Nuclear' wheel covers (set of four)
- Chrome door handles
- Chrome door sill protector
- Chrome side rubbing strips
- Leather steering wheel

DSTYLE

DYNAMIC IN DETAIL

FROM NOSE TO TAIL CITROËN DS3 DSTYLE FEATURES EXCLUSIVE DETAILS AND STYLING FLOURISHES, FROM ITS LEDS TO INTERIOR MOOD LIGHTING AND DARK TINTED WINDOWS. EVERY ELEMENT HAS BEEN METICULOUSLY CHOSEN TO HEIGHTEN CITROËN DS3'S SENSORY IMPACT. AND IT'S EVEN AVAILABLE AS A 95G/KM CO₂ MODEL.

> CITROËN DS3 **DSTYLE 95G** SPECIFICATION IN ADDITION TO DSIGN INCLUDES:

- Air conditioning
- Interior mood lighting
- **LED Signature** – daytime-running LEDs, front fog lights and grille chrome surrounds and chrome insert on rear number plate moulding
- Scented air freshener
- Dark tinted rear windows

> CITROËN DS3 **DSTYLE** SPECIFICATION IN ADDITION TO DSIGN 95G INCLUDES:

- 16" 'Ashera' alloy wheels (set of four)

DSPORT

THE ULTIMATE

THE DEFINITIVE CITROËN DS3 MIXES LAVISH DETAILS, EYE CATCHING STYLE, INGENIOUS TECHNOLOGY AND FINE MATERIALS TO CREATE THE ULTIMATE FORMULA. ALL THAT'S LEFT TO DO IS ADD YOU.

> CITROËN DS3 **DSPORT** SPECIFICATION IN ADDITION TO DSTYLE INCLUDES:

- Automatic digital air conditioning
- Contrasting body/roof colour
- **Connect Signature** – Connecting Box (Bluetooth® system with USB socket) and Hi-Fi system
- Anti-theft alarm
- 17" black 'Bellone' alloy wheels (set of four)
- Citroën eTouch Emergency & Assistance System
- Rear spoiler with an integrated third brake light
- Double chrome exhaust pipe
- Front and rear carpet mats
- Aluminium drilled pedals

	CO ₂ EMISSIONS (G/KM)			
	DSign	DStyle 95g	DStyle	DSport
PETROL ENGINE AVAILABILITY				
VTi 95 manual	134			
VTi 120 manual			136	
VTi 120 automatic			153	
THP 155 6-speed manual				139
DIESEL ENGINE AVAILABILITY				
e-HDi 90 Airdream manual		95	98	
e-HDi 110 Airdream 6-speed manual				99



THE PERSONAL JOURNEY: OUTSIDE.
THE POSSIBILITIES ARE ENDLESS...
CITROËN DS3 PRESENTS A MULTITUDE
OF WAYS TO MAKE IT A VERY
PERSONAL CHOICE. ONCE YOU'VE
CHOSEN FROM 11 STUNNING BODY
COLOURS, IT'S TIME TO CONSIDER A
SHADE FOR THAT 'FLOATING' ROOF.
TAKE YOUR TIME; THERE ARE 34
POTENTIAL COMBINATIONS...

› DOOR MIRROR COLOURS



> KEY COLOURS



ROOF COLOURS

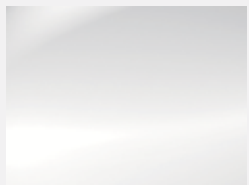

White



Black



Carmen Red



Fuchsia Pink

16" 'NUCLEAR'
WHEEL COVERS
Set of four
Tyres: 195/55 R16



16" 'ASHERA'
ALLOY WHEELS
Set of four
Tyres: 195/55 R16



17" BLACK 'BELLONE'
ALLOY WHEELS
Set of four
Tyres: 205/45 R17



BODY COLOURS



Polar White



Botticelli Blue



Sport Red



Sport Yellow



Shark Grey (M)



Arctic Steel (M)



Manitoba Grey (M)



Belle Ile Blue (M)



Perla Nera Black (P)



Cherry Red (P)



Hickory Brown (P)

(P) Pearlescent
(M) Metallic

Please note: Colours and pictures shown are for illustration purposes only. Please consult your Dealer for definitive colour and trim/upholstery details. Please check the Citroën DS3 'Touch' brochure for availability, cost and the full range of wheels.

THE PERSONAL JOURNEY: INSIDE.
INDULGE YOUR SENSES INSIDE CITROËN DS3 AND CREATE AN INTERIOR THAT REFLECTS YOU. EVERY DETAIL CAN BE FINE TUNED TO YOUR TASTES, FROM SUMPTUOUS, SPORTY LEATHER SEAT TRIMS TO FLOOR MATS THAT MATCH YOUR CHOSEN ROOF GRAPHIC.



> TRIMS

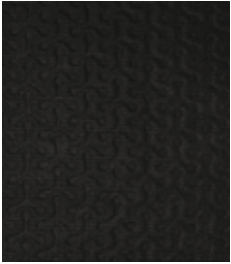

Mistral 'Sturm' cloth



Mistral 'Rayados' cloth

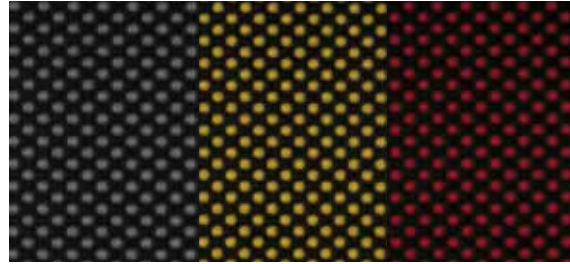

'Akinen' cloth and mistral Alcantara®
in Sirocco, Sport Yellow or Sport Red

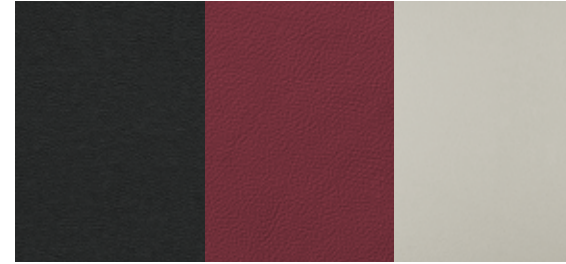

Perforated 'Claudia' leather
in Mistral, Amarante or Lama/Mistral

> MATS



Vibe



Zebra



Plane



Co-Design



Flavio



Pearl



Urban Tribe



Map



Flower

> GEAR LEVERS



> DASHBOARDS



EQUIPMENT SPECIFICATION

	DSign	DStyle 95g	DStyle	DSport
SAFETY & SECURITY				
ABS with Electronic Brakeforce Distribution (EBD) and Emergency Braking Assistance (EBA)	●	●	●	●
Electronic Stability Programme (ESP)	●	●	●	●
Driver's airbag	●	●	●	●
Front passenger's airbag with cut-off device	●	●	●	●
Front lateral airbags	●	●	●	●
Curtain airbags	●	●	●	●
Front seat belt pre-tensioners with force-limiters	●	●	●	●
Five 3-point inertia reel seat belts	●	●	●	●
Warning lights and audible warning system for driver's 'unfastened' seat belt	●	●	●	●
Automatic activation of hazard warning lights (in case of rapid deceleration or impact)	●	●	●	●
High-frequency remote control central locking with deadlocks	●	●	●	●
Automatic door and boot locking (when car in motion)	●	●	●	●
Outer rear Isofix child seat anchorage points	●	●	●	●
Cruise control with speed limiter	●	●	●	●
Anti-theft alarm	●	●	●	●
Citroën eTouch Emergency & Assistance System	●	●	●	●

Please check the Citroën DS3 'Touch' brochure for further equipment availability and cost.

- Standard equipment
- Optional factory fitted equipment

¹ Available only as part of optional LED Signature.

² Available only as part of optional City or eMyWay City Signatures.

³ Excludes automatic model.

⁴ Perla Nera Black only.

⁵ Available only when optional Sirocco 'Akinen' and mistral Alcantara® cloth is ordered.

⁶ Available only as part of optional 'Vibe', 'Zebra', 'Pearl', 'Urban Tribe', 'Map', 'Plane', 'Co-Design', 'Flavio' or 'Flower' Spirits.

⁷ Available only as part of eMyWay, City or eMyWay City Signatures.

⁸ Mobile phone compatibility can vary by phone manufacturer. Please consult your Dealer for further compatibility information.

⁹ Includes air conditioning.

	DSign	DStyle 95g	DStyle	DSport
LIGHTING & VISIBILITY				
Halogen headlamps	●	●	●	●
Electrically adjustable door mirrors	●	●	●	●
LEDs	○ ¹	●	●	●
Boot light	●	●	●	●
Front courtesy reading lights	●	●	●	●
Front fog lights	●	●	●	●
Interior mood lighting	○ ²	●	●	●

	DSign	DStyle 95g	DStyle	DSport
DRIVER INFORMATION				
Multi-function on-board trip computer (current fuel consumption, average fuel consumption, distance covered, average speed and range on remaining fuel)	●	●	●	●
Gear Efficiency Indicator (GEI)	●	●	● ³	●
Puncture repair kit	●	●	●	●
Exterior temperature display	●	●	●	●
'Black panel' nighttime instrument lighting	●	●	●	●

	DSign	DStyle 95g	DStyle	DSport
STYLE				
EXTERIOR				
16" 'Nuclear' wheel covers (set of four)	●	●	●	●
16" 'Ashera' alloy wheels (set of four)	●	●	●	●
17" black 'Bellone' alloy wheels (set of four)	●	●	●	●
Matching body/roof colour	●	●	●	○ ⁴
Contrasting body/roof colour	○	○	○	●
Rear spoiler with an integrated third brake light	●	●	●	●
Double chrome exhaust pipe	●	●	●	●
Chrome door handles	●	●	●	●
Roof colour painted door mirrors with chrome base	●	●	●	●
Chrome front fog light surrounds	○ ¹	●	●	●
Chrome front grille surround	○ ¹	●	●	●
Chrome insert on rear number plate moulding	○ ¹	●	●	●
Chrome side rubbing strips	●	●	●	●
Dark tinted rear windows	○ ⁵	●	●	●
INTERIOR				
'Soft-touch' effect upper dashboard	●	●	●	●
Aluminium effect dashboard	●	●	●	●
Shiny black dashboard	●	●	●	●
Carbon fibre effect dashboard	●	●	●	●
Leather steering wheel with aluminium effect inserts	●	●	●	●
Leather steering wheel with chrome inserts	●	●	●	●
Shiny black painted centre console	●	●	●	●
Chrome door sill protector	●	●	●	●
Front and rear carpet mats	○ ⁶	○ ⁶	○ ⁶	●
Aluminium drilled pedals	○ ⁵	○ ⁵	○ ⁵	●

	DSign	DStyle 95g	DStyle	DSport
STORAGE				
Front door pockets with bottle holder	●	●	●	●
Front seat back pockets	●	●	●	●
Rear side pockets	●	●	●	●
Lashing eye in the boot	●	●	●	●

	DSign	DStyle 95g	DStyle	DSport
COMFORT & CONVENIENCE				
Variable power assisted steering	•	•	•	•
Sport suspension	•	•	•	•
Height and reach adjustable steering wheel	•	•	•	•
Scented air freshener	•	•	•	•
12 volt socket	•	•	•	•
Air recirculation and pollen filter	•			
Driver's and passenger's sunvisor with courtesy mirror	•			
Driver's and passenger's sunvisor with covered, illuminated courtesy mirror		•	•	•
Front electric windows with 'one-touch' operation on driver's side	•	•	•	•
Air conditioning	•	•	•	•
Automatic digital air conditioning	o ⁷	o ⁷	o ⁷	•

	DSign	DStyle 95g	DStyle	DSport
SEATING				
Height-adjustable driver's seat	•	•	•	•
Height-adjustable front passenger's seat	•	•	•	•
Three rear head restraints	•	•	•	•
Rear 1/3-2/3 split/folding seats	•	•	•	•
IN-CAR ENTERTAINMENT				
RDS stereo radio/MP3 compatible CD player with steering mounted controls	•	•	•	•
Auxiliary socket	•	•	•	•
Six speakers	•	•	•	•
Connect Signature – Connecting Box (Bluetooth® system with USB socket) and Hi-Fi system	o ^{8/9}	o ⁸	o ⁸	• ⁸



TECHNICAL SPECIFICATION



78.5mpg
on e-HDi 90 Airdream
manual 95g model



95g/km CO₂
on e-HDi 90 Airdream
manual 95g model

	PETROL MODELS			
	VTi 95 manual	VTi 120 manual	VTi 120 automatic	THP 155 6-speed manual
ENGINE				
Capacity (cc)	1397	1598	1598	1598
Cylinders	4 in line	4 in line	4 in line	4 in line
Max power CEE (kW/rpm)	70/6000	88/6000	88/6000	115/6000
Max torque CEE (Nm/rpm)	135/4000	160/4200	160/4200	240/1400
Fuel system	Multi-point electronic fuel injection	Multi-point electronic fuel injection	Multi-point electronic fuel injection	Multi-point electronic turbocharged fuel injection
Euro status	Euro 5	Euro 5	Euro 5	Euro 5
TRANSMISSION				
Four speed automatic			•	
Five speed manual	•	•		
Six speed manual				•
Clutch type	Dry single plate	Dry single plate	N/A	Dry single plate
<small>(All figures driver alone)</small> PERFORMANCE				
Max speed (mph)	114	118	118	133
0-62mph (secs)	10.6	8.9	10.9	7.3
Standing 1000m (secs)	32.2	30.3	32.4	28.2
<small>(Official Government test fuel consumption figures)</small> ECONOMY Litres/100km (mpg)				
Urban cycle	7.6 (37.2) – 7.7 (36.7) [▲]	7.9 (35.8) – 8.0 (35.3) [▲]	9.4 (30.1) – 9.5 (29.7) [▲]	8.2 (34.4)
Extra urban	4.8 (58.9) – 4.9 (57.6) [▲]	4.8 (58.9) – 4.9 (57.6) [▲]	5.0 (56.5) – 5.1 (55.4) [▲]	4.7 (60.1)
Combined	5.8 (48.7) – 5.9 (47.9) [▲]	5.9 (47.9) – 6.0 (47.1) [▲]	6.6 (42.8) – 6.7 (42.2) [▲]	6.0 (47.1)
CO₂ EMISSIONS (g/km)				
	134 – 136 [▲]	136 – 138 [▲]	153 – 155 [▲]	139
<small>Please note: the maximum plated weights must not be exceeded</small> WEIGHTS (kg)				
Mass in service	1194	1189	1222	1223
Max laden weight	1552	1554	1587	1590
Max towing weight braked/unbraked	1150/570	1150/570	1150/570	1150/570
Max roof rack load	70	70	70	70
BRAKES				
	ABS with EBD and EBA standard on all models			
Front discs, rear drums	•			
Front discs, rear discs		•	•	•
STEERING				
	Variable power assisted steering			
Number of turns lock to lock	3.1	3.1	3.1	3.1
Turning circle between kerbs (m)	10.2	10.2	10.4	10.4
SUSPENSION				
	Pseudo MacPherson strut front with deformable beam rear			
FUEL TANK CAPACITY Litres (gallons)				
	48 (10.6)			
EXTERIOR DIMENSIONS (mm)				
Length/Width/Height/Wheelbase	3948/1715/1483/2464			
BOOT VOLUMES & DIMENSIONS				
Seats up – below parcel shelf max (litres VDA)	285			

[▲] When optional 17" 'Bellone' alloy wheels are ordered.

DIESEL MODELS

e-HDi 90 Airdream manual 95g	e-HDi 90 Airdream manual	e-HDi 110 Airdream 6-speed manual
1560	1560	1560
4 in line	4 in line	4 in line
68/4000	68/4000	82/3600
230/1750	230/1750	270/1750
High pressure direct diesel injection	High pressure direct diesel injection	High pressure direct diesel injection
Euro 5	Euro 5	Euro 5
•	•	•
Dry single plate	Dry single plate	Dry single plate
113	113	118
12.5	12.5	9.7
34.2	34.2	31.4
4.3 (65.7)	4.4 (64.2)	4.6 (61.4)
3.2 (88.3)	3.3 (85.6)	3.4 (83.1)
3.6 (78.5)	3.7 (76.3)	3.8 (74.4)
95	98	99
1160	1160	1256
1625	1625	1625
1150/570	1150/570	1150/570
70	70	70
ABS with EBD and EBA standard on all models		
•	•	•
Variable power assisted steering		
3.1	3.1	3.1
10.4	10.4	10.4
Pseudo MacPherson strut front with deformable beam rear		
48 (10.6)		
3948/1715/1483/2464		
285		



A NEW DIMENSION. THE CHOICE OF TECHNOLOGY AND MULTIMEDIA EQUIPMENT AVAILABLE FOR CITROËN DS3 TAKES YOU TO A NEW DIMENSION OF COMFORT, CONVENIENCE AND ENJOYMENT TOGETHER IT CREATES A DRIVING ENVIRONMENT LIKE NOTHING ELSE.

VISIT WWW.ACCESSORIES.CITROEN.CO.UK TO VIEW THE FULL RANGE OF CITROËN DS3 ACCESSORIES.



> WIFI ON BOARD

Offers wireless internet connectivity. WiFi On Board system will enable multiple devices to connect to the internet whilst on the move or when the vehicle is stationary through a 3G/3G+ SIM Card.

Requires a 3G/3G+ SIM, which is not included.

> TOMTOM CHOICE

Choose from two TomTom Start 20 models. Both Start 20 UK & ROI and Start 20 Europe include plenty of great features such as 4.3" high quality touch screen, IQ routes and Advanced lane guidance.

> EXTERIOR HIGHLIGHTS

There is a range of exterior accessories that add highlights and flourishes to your new Citroën DS3. They include chrome headlight sub-deflectors and chrome door mirror covers, plus a rear spoiler with integrated third brake light.



MP3 ADAPTOR

Installed in the glovebox, the MP3 Adaptor allows the connection of an MP3 player and USB stick. It can be activated from controls under the steering wheel or from the original radio.

MP3 player not included.



ROOFSCAPES

Select your individual roof from these striking designs.



ALLOY WHEELS

Along with the 17" 'Bellone' alloy wheels shown, the 16" 'Valonga' and 16" 'Ashera' alloys are also available.



EFFICIENCY MINUS COMPROMISE. CITROËN HAS CREATED FUELEFFICIENT VEHICLES WITHOUT SACRIFICING DRIVER ENJOYMENT FOR SOME TIME. THE LATEST ADVANCES TAKE THIS FINE BALANCE FURTHER STILL...

WITH THE PROVEN CREDENTIALS AND ENVIRONMENTAL PERFORMANCE OF CITROËN HDi DIRECT INJECTION ENGINES AS INSPIRATION, e-HDi ADDS NEW TECHNOLOGY, SUCH AS A SMOOTH, SIMPLE STOP & START SYSTEM AND EGS GEARBOX. THE RESULTS ARE A DRAMATIC REDUCTION IN BOTH FUEL CONSUMPTION AND CO₂ EMISSIONS, COMBINED WITH RESPONSIVE PERFORMANCE WHEREVER YOU GO.



We've also been equipping more of our vehicles with more environmentally friendly breakthroughs, such as our Electronic Gearbox System (EGS), which boasts impressively greener credentials, with less pollution and up to 5% more economy than a conventional manual gearbox system. In addition, Citroën has expanded the use of the exceptionally efficient, self-regenerating Diesel Particulate Filter System in our models. Cleaner, greener driving without taking away from the drive – that's what you can continue to expect from Citroën.



ELECTRIFYING. HOWEVER YOU LOOK AT IT

Forget what you know about electric cars. Citroën Survolt concept combines undiluted glamour with advanced sporting dynamics, then adds a 100% electric drivetrain. Outside, LED lights, voluptuous curves, two-tone charcoal and fuchsia paintwork, and a race-inspired rear spoiler meet your gaze. Inside, a stunning blend of curved chrome, swooping glass, high technology and organic forms welcomes you to an entirely new place. But this is no simple styling exercise. At heart, Survolt is even more radical, because although it is designed to thrill, it is powered purely by silent, efficient, clean electricity.

AIRDREAM – A BENCHMARK

When it comes to the environment we wanted to show our genuine commitment as well as our profound expertise, so we have devised a benchmarking scheme with the signature 'Airdream'. To qualify for the Airdream signature, vehicles must have an e-HDi, electric or Hybrid4 engine.

DRIVE YOUR WAY. GET BEHIND THE WHEEL OF YOUR NEW CITROËN DS3, WITH CITROËN'S RANGE OF FINANCE AND INSURANCE PRODUCTS.

CITROËN FINANCIAL SERVICES

PURCHASE PLAN
Own your vehicle with this flexible package designed to fit your budget.

ELECT 3
A new Citroën car every two or three years with monthly payments structured to suit your budget.

ELECT 4
Enjoy the convenience of a new car without the stress and hassle of ownership.

TO FIND OUT MORE ABOUT CITROËN PRODUCTS AND SERVICES, GO TO WWW.CITROEN.CO.UK OR CONTACT YOUR CITROËN DEALER.

FOR BUSINESS USERS

CITROËN CONTRACT MOTORING

HIRE PURCHASE
A tried and tested finance package that allows you to own your vehicle.

BUSINESS LEASE
An alternative to vehicle ownership that allows you to control your business cash flow and gain tax efficiencies.

LEASE PURCHASE
Own a vehicle with a finance solution that offers ultimate flexibility to complement your business cash flow.

CONTRACT HIRE
A non-ownership finance solution that keeps costs fixed and risks low.

FOR MORE INFORMATION ON CITROËN FLEET AND BUSINESS SALES, PLEASE CALL CITROËN FLEET CONNECT ON 08457 940 940 OR LOOK US UP AT WWW.CITROEN.CO.UK/FLEET

CITROËN INSURANCE

INSTANT COVER
To help you drive away your new car without delay, we offer Instant Cover insurance, providing you with 7 days comprehensive car insurance, for free!

MOTOR INSURANCE
Citroën Insurance has been designed specifically for our vehicles. You don't just get repairs you get Citroën expertise, service, quality and parts. So, when the time comes to renew your insurance cover, call Citroën Insurance on 0870 024 2725.

Lines open 8am - 8pm weekdays, 9am - 5pm Saturdays.
Max call charge from a BT landline is 8p per minute.
Calls from other networks may vary. Alternatively, visit www.citroen.co.uk for more information or to apply online.

Citroën Insurance is underwritten by UK Insurance Ltd which is authorised and regulated by the Financial Services Authority. Citroën Insurance is a trading style of Banque PSA Finance UK of Quadrant House, Princess Way, Redhill, Surrey, RH1 1QA.

ESSENTIAL CARE. CITROËNS ARE RENOWNED FOR THEIR RELIABILITY – AND NEW CITROËN DS3 IS NO EXCEPTION.

WITH THE ADDED REASSURANCE OF A WARRANTY, ROUTINE SERVICING AND MAINTENANCE, AS WELL AS 24-HOUR ROADSIDE ASSISTANCE, YOU ARE PROTECTED.

CITROËN WARRANTY

Every new Citroën car has the benefit of a 3 year* warranty package, plus a 12 year anti-perforation** warranty and a 3 year paint warranty.

* 2 years' unlimited warranty. No-fee customer option of 1 year's Dealer provided warranty, only on cars sourced from Citroën UK Limited. Note: Dealer provided warranty is limited to 60,000 miles for cars.

** Against all internal to external perforation to bodywork or underbody.

CITROËN ASSISTANCE

In response to a free telephone call in the UK, Citroën Assistance brings rapid expert roadside assistance to you in an emergency. It comes free of charge for a full year and operates 24 hours a day in all parts of the UK and Europe. Services include nationwide recovery for both car and passengers, a home call service, replacement vehicle, hotel accommodation and vehicle storage if required. Please note, Citroën Assistance only applies to incidents covered by the new vehicle warranty, and excludes non-vehicle faults, such as running out of fuel, mis-fuelling, loss of keys, lock-ins, road traffic accidents and punctures/wheel changes.

Full details are available on request from Citroën UK via cuk_contactcentre@citroen.com

CITROËN MAINTENANCE

From roadside assistance to replacing wear and tear parts or regular servicing, with Citroën Maintenance you have total peace of mind. For a one-off fee or low monthly payment, our experienced engineers will take care of your Citroën, whatever happens.

To find out more, contact your Citroën Dealer or Citroën Authorised Repairer.

CITROËN SERVICING

Available up to 1 year from your vehicle's registration date, but before its first chargeable service, a Citroën Servicing Package enables you to pay in advance for your vehicle's servicing needs for 3 years/35,000 miles.

For further information, please contact your Citroën Dealer.

GLOSSARY

> e-HDi DIESEL ENGINE

The e-HDi 90 Airdream manual engine is capable of up to 78.5mpg and CO₂ emissions of as little as 95g/km. It has a reversible starter-alternator that works in tandem with an e-booster to provide a seamless Stop & Start function. Going further than other similar systems, the e-HDi's Stop & Start puts the engine into idle mode while decelerating before coming to a complete standstill. This reduces consumption by 15% in urban driving.

> ANTI-LOCK BRAKING SYSTEM (ABS)

Computer-controlled braking assistance designed to prevent the wheels from locking under extreme braking. This enables the car to continue being steered and therefore controlled during this braking incident. The Citroën DS3's ABS system is further enhanced with EBA and EBD.

> ELECTRONIC BRAKEFORCE DISTRIBUTION (EBD)

A conventional ABS system cannot account for any of the four wheels wanting to lock more quickly than the others (for example, two of the wheels may be on snow and two on tarmac). EBD reads the deceleration rate of each wheel individually and applies the ABS principles accordingly.

> EMERGENCY BRAKING ASSISTANCE (EBA)

As drivers we find it difficult to instinctively brake very hard, but this is often what is needed in those rare emergency situations. The EBA system recognises our 'attempt' to brake hard and in combination with the ABS and EBD systems instantly applies the maximum stopping power possible.

> ELECTRONIC STABILITY PROGRAMME (ESP)

This is computer-controlled traction assistance and is provided primarily through the braking systems. The ESP's control unit constantly compares where the driver intends going (through the position of the steering wheel) with where the vehicle is actually going and, if necessary, makes speed corrections to each wheel individually through braking or engine torque to keep the vehicle 'in line'.

> EMYWAY SATELLITE NAVIGATION SYSTEM

The eMyWay satellite navigation system features a 7" screen and covers UK and Europe. Its in-built memory provides information about speed limits and lets you know which lane to use when reaching complex intersections. The system also lets you adapt your route based on traffic conditions, with data provided by Trafficmaster and ViaMichelin in the UK and France.

> ON-BOARD TRIP COMPUTER

The Citroën DS3's multi-function on-board trip computer provides you with information at your fingertips. At the touch of a button you can view a range of data like fuel consumption, average speed and mileage possible at your current fuel level.

> VARIABLE POWER ASSISTED STEERING

A system that provides extra power assistance for a vehicle's steering at low speeds (such as turning a sharp corner) and less assistance during high-speed situations.

> CITROËN ETOUCH EMERGENCY AND ASSISTANCE SYSTEM

In the event of an accident or sudden health problem, one push of the 'SOS' button will instantly contact the emergency services. If there's a more serious incident, SOS activates automatically. After a breakdown, one push on the 'chevron' button will alert Citroën Assistance, sending both location details and an initial fault report.

> RADIO DATA SYSTEM (RDS)

Traffic information on FM radio, allowing the station name and other information to be transmitted alongside audio information.

> FRONT SEAT BELT PRE-TENSIONERS

In the event of a crash, a pre-tensioner will tighten the seat belt almost instantaneously. This reduces the load on the occupant in a violent crash. Like airbags, pre-tensioners are triggered by sensors in the car's body, and use explosively expanding gas to drive a piston that retracts the belt. Seat belt pre-tensioners also lower the risk of 'submarining', which is when a passenger slides forward under a loosely worn seat belt.

> ISOFIX

A standardised and more simple method for installing child seats, each seat is 'clicked' into place via a three point system. On Citroën DS3, Isofix is installed on the outer rear seats.

DIMENSIONS

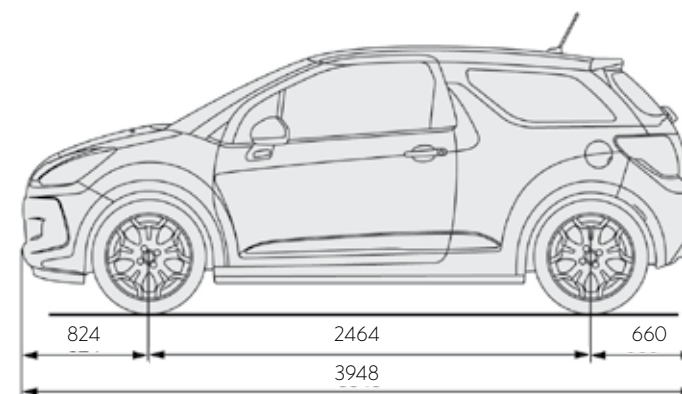
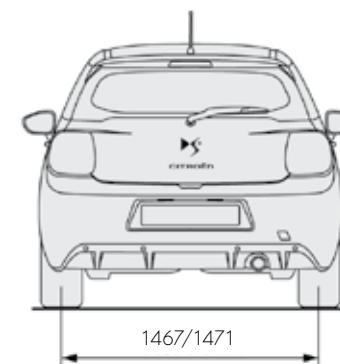
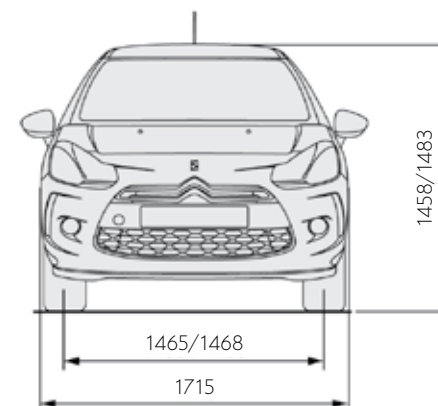

All measurements are in millimetres.



This brochure is made from paper from a well-managed forest. Citroën support responsible use of forest resources.

Please don't throw me away, give me to a friend or recycle me.

NOTE: Every endeavour has been made to ensure that the information and details contained in this brochure were accurate at the time of going to press July 2012. However the company reserves the right, whilst preserving the essential characteristics of the models described, to introduce at any time modifications, changes of details, equipment or accessories. Every effort will be made to bring this brochure up to date, but in order to avoid any misunderstandings please consult your Dealer. For full details of Citroën Care for Car and Driver, please see the full manufacturer's price list. The Citroën Website contains full information on all Citroën products and offers available in the UK, together with details of our environmental and recycling policies. The site address is: www.citroen.co.uk or you can contact Citroën directly via cuk_contactcentre@citroen.com

CITROËN prefers TOTAL

CITROËN UK Ltd. 221 Bath Road, Slough SL1 4BA.
www.citroen.co.uk

CRÉATIVE TECHNOLOGIE

